

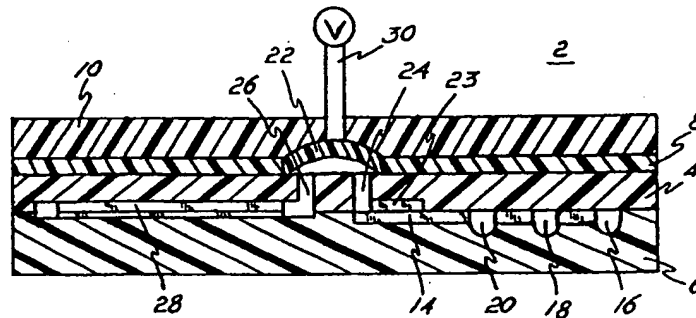

INTERNATIONAL APPLICATION PUBLISHED UNDER THE PATENT COOPERATION TREATY (PCT)

<p>(51) International Patent Classification <sup>6</sup> : B01L 3/00, B32B 27/34</p>	<p>A1</p>	<p>(11) International Publication Number: <b>WO 99/03584</b>  (43) International Publication Date: 28 January 1999 (28.01.99)</p>
<p>(21) International Application Number: PCT/US98/14950 (22) International Filing Date: 20 July 1998 (20.07.98) (30) Priority Data: 08/897,744 21 July 1997 (21.07.97) US (71) Applicant: YSI INCORPORATED [US/US]; 1700/1725 Bran- num Lane, P.O. Box 279, Yellow Springs, OH 45387 (US). (72) Inventor: MOLES, Donald, R.; 2721 Cedarville-Yellow Springs Road, Cedarville, OH 45314 (US). (74) Agents: LEVY, Mark, P. et al.; Thompson, Hine &amp; Flory LLP, 2000 Courthouse Plaza, N.E., P.O. Box 8801, Dayton, OH 45401-8801 (US).</p>	<p>(81) Designated States: AL, AM, AT, AU, AZ, BA, BB, BG, BR, BY, CA, CH, CN, CU, CZ, DE, DK, EE, ES, FI, GB, GE, GH, GM, HU, ID, IL, IS, JP, KE, KG, KP, KR, KZ, LC, LK, LR, LS, LT, LU, LV, MD, MG, MK, MN, MW, MX, NO, NZ, PL, PT, RO, RU, SD, SE, SG, SI, SK, SL, TJ, TM, TR, TT, UA, UG, UZ, VN, YU, ZW, ARIPO patent (GH, GM, KE, LS, MW, SD, SZ, UG, ZW), Eurasian patent (AM, AZ, BY, KG, KZ, MD, RU, TJ, TM), European patent (AT, BE, CH, CY, DE, DK, ES, FI, FR, GB, GR, IE, IT, LU, MC, NL, PT, SE), OAPI patent (BF, BJ, CF, CG, CI, CM, GA, GN, GW, ML, MR, NE, SN, TD, TG).</p> <p><b>Published</b> <i>With international search report.</i></p>	

(54) Title: MICROFLUIDIC ANALYZER MODULE



(57) Abstract

A microfluidic analyzer module. The module is constructed of a plurality of channel forming laminate layers that are directly bonded together without adhesive or other possible contaminant source located proximate the flow channels. The channel forming laminate layers define a network of fluid flow channels. A valve containing layer is directly, adhesivelessly bonded over the channel containing layers. A flexible valve member integral with the valve layer opens and closes communication between feed and sensor channels of the channel network.

**FOR THE PURPOSES OF INFORMATION ONLY**

Codes used to identify States party to the PCT on the front pages of pamphlets publishing international applications under the PCT.

AL	Albania	ES	Spain	LS	Lesotho	SI	Slovenia
AM	Armenia	FI	Finland	LT	Lithuania	SK	Slovakia
AT	Austria	FR	France	LU	Luxembourg	SN	Senegal
AU	Australia	GA	Gabon	LV	Latvia	SZ	Swaziland
AZ	Azerbaijan	GB	United Kingdom	MC	Monaco	TD	Chad
BA	Bosnia and Herzegovina	GE	Georgia	MD	Republic of Moldova	TG	Togo
BB	Barbados	GH	Ghana	MG	Madagascar	TJ	Tajikistan
BE	Belgium	GN	Guinea	MK	The former Yugoslav Republic of Macedonia	TM	Turkmenistan
BF	Burkina Faso	GR	Greece			TR	Turkey
BG	Bulgaria	HU	Hungary	ML	Mali	TT	Trinidad and Tobago
BJ	Benin	IE	Ireland	MN	Mongolia	UA	Ukraine
BR	Brazil	IL	Israel	MR	Mauritania	UG	Uganda
BY	Belarus	IS	Iceland	MW	Malawi	US	United States of America
CA	Canada	IT	Italy	MX	Mexico	UZ	Uzbekistan
CF	Central African Republic	JP	Japan	NE	Niger	VN	Viet Nam
CG	Congo	KE	Kenya	NL	Netherlands	YU	Yugoslavia
CH	Switzerland	KG	Kyrgyzstan	NO	Norway	ZW	Zimbabwe
CI	Côte d'Ivoire	KP	Democratic People's Republic of Korea	NZ	New Zealand		
CM	Cameroon			PL	Poland		
CN	China	KR	Republic of Korea	PT	Portugal		
CU	Cuba	KZ	Kazakstan	RO	Romania		
CZ	Czech Republic	LC	Saint Lucia	RU	Russian Federation		
DE	Germany	LI	Liechtenstein	SD	Sudan		
DK	Denmark	LK	Sri Lanka	SE	Sweden		
EE	Estonia	LR	Liberia	SG	Singapore		

## MICROFLUIDIC ANALYZER MODULE

### Field of the Invention

The present application is directed to a fluid flow module that allows for analyte sample flow therethrough while providing a situs for the location of a sensing element or elements therein to detect analyte presence and/or concentration. The module is designed for microfluidic flow rates and volumes and can be discarded after use with simple replacement by another module.

### Background of the Invention

Microfluidic analyzers have been used to sense a plurality of analytes in whole blood, diluted blood, plasma or serum. Additionally in the rapidly growing fields of cell culture growth and fermentation, it is often necessary to measure glucose, glutamine, lactate,  $\text{NH}_3$  phosphate and iron in micro-scale fluid flow analysis systems.

Due to the scarce and often expensive nature of the fluid medium containing the analyte, it is imperative that the fluid medium should be conserved with only the smallest amounts used for the analysis. Also, the emphasis toward in-situ measurement of biological fluids such as cell culture media dictates that the analytical equipment should not only be small in size, but component parts of the analytical system should also be designed for easy removal from the system and rapid replacement of a new component part to the system so that cleanliness of the component can be accurately controlled without interruption in the monitoring effort. Moreover, such a component or assembly itself should be as free from contamination itself as possible.

There are several additional reasons why the measurement of sterile biological fluids benefit from the use of a disposable microfluidic; for the measurement of sterile fluids the measurement system should be enclosed, i.e. all wetted parts should be sealed so that they may be sterilized and remain that way during monitoring. If the entire fluidic system (including sensor, reagents and waste) is to be enclosed then economics dictate that it should be small, preferably very small.

Another aspect of the micro approach responds to the above-noted need to consume only small amounts of samples. If small amounts of sample are withdrawn for analysis then

small conduits are needed to convey the sample to the analyzer in order to deliver a timely result. This can be accomplished in two ways: first the conduit should be small in diameter, secondly it should be as short as possible. The best way to keep the sample conduit short is to move the analyzer to the sample. The only practical way to accomplish this is to develop the analyzer and conduit on a micro scale.

#### Summary of the Invention

The present invention is therefore directed to an easily assembled and manufactured microfluidic analyzer module that is adapted for easy interchangeability with a previously utilized module so that, if desired, the technician or scientist can disconnect the module and easily replace it with another. Additionally, the module itself is constructed of a plurality of directly bonded polymer layers in a sandwich laminate structure wherein the interfacial surface areas of the laminate have been etched or otherwise formed into a network of communicating microflow channels. Typically, the channels are trough-like recesses adapted for microfluid flow therein and may have widths of about .001 - .015" with channel depths being about .0005 - .015".

The module is preferably constructed of thin polymeric, laminate layers that are bonded together to form the laminate without the use of adhesives or glues that are normally used in adhesive bonding of laminate layers. This fact is especially important in critical analytical operations. Quite obviously, the presence of undesired contaminant molecules, especially those proximate the fluid containing channels, interferes with accuracy of the analytical determination.

The use of adhesives, because of the reduced scale involved, also compromises geometry. Adhesives, if liquid, tend to flow into channels, if dry, they tend not to be patternable which means that they can be mis-registered, which leads to voids along the channel or sensor cavities. These voids are "dead" volumes which destroy the desirable properties of the flow channel and make the behavior of the system less reproducible from system to system.

Further, the individual layers of the laminate can be subjected to high resolution microlithographic etching or other high resolution etching methods. When these layers are contiguously placed and bonded to each other in a sandwich construction they define a

network of small or micro dimensioned channels with certain channel portions formed in a surface area of one laminate layer and other channel portions formed in the contiguous surface area of an adjacent laminate layer. A thin, polymeric valve layer is also provided as part of the laminate structure. The valve layer is securely bonded over the sandwich construction over all surface areas except those in which valving action must occur. That is, in those areas of the sandwich in which valving action is needed to selectively block or open communication between channels of the network, an overlying flexible polymer valve is provided with flexing of the polymer valve against the underlying laminate layer surface functioning to open or block channel communication.

In accordance with the invention, complex three dimensional structures can be constructed from layers, with the benefit that each layer can be treated as a planar, two dimensional, entity. This is significant because of the extensive capabilities which have been developed which support the micromachining of planar substrates. The ability to build these layers into three dimensional structures requires not only bondability but the use of techniques of registration and bonding which preserve the integrity of the micro features themselves.

The materials used to form the module are inert, micro-machinable, bondable and dimensionally stable. Additionally, metal layers may be readily provided over these materials. This is an important consideration in regard to the desirable integration of sensor and fluidic.

The invention will be further described in conjunction with the appended drawings and following detailed description.

#### Brief Description of the Drawings

Fig. 1A is a plan view of a microfluidic analyzer module in accordance with the invention;

Fig. 1B is a sectional view of the microfluidic analyzer module shown in Fig. 1A taken along the plane represented by the lines and arrows 1B-1B thereof;

Fig. 1C is a sectional view of the microfluidic analyzer module similar to that shown in Fig. 1B, but here showing positioning of the valve member in the open position to allow communication between certain channels of the fluid network;

Fig. 2 is a sectional view of the microfluidic analyzer module taken along the plane represented by the lines and arrows 2-2 of Fig. 1B;

Fig. 3 is a sectional view taken along the plane represented by the lines and arrows 3-3 of Fig. 1B;

Fig. 3A is a magnified view of a portion of Fig. 3 showing the disposition of the sensor electrodes in the sensing channel;

Fig. 4 is a diagrammatical section view of another microfluidic flow analyzer module taken through a plane represented by the valve layer thereof which valve layer is disposed similarly to the valve layer disposition shown in Fig. 1B;

Fig. 5 is a schematic view of a press bonding autoclave that may be used in accordance with the invention to pressure bond layers of the microfluidic analyzer module; and

Fig. 6 is a plan view of a platen that may be used to pressure bond the valve layer over the channel containing layers of the microfluidic analyzer module.

#### Detailed Description of the Preferred Embodiment

Turning now to Figs. 1A and B of the drawings, there is shown a microfluidic analyzer module 2 of the present invention comprising an upper polymer layer 4 superposed over lower polymer layer 6. As shall be explained later, the layers 4 and 6 are channel bearing layers in that they will be etched or otherwise provided with channels or portions of channels therein. Upon mating of the layers 4, 6 in superposition, a channel network is formed. A polymeric valve layer 8 is disposed on top of the layer 4 so as to selectively open and shut fluid ingress and egress channels to allow fluid flow therebetween and through the module.

As shown, lower polymer layer 6 is provided with an inlet channel 14 therein which, may be formed by suitable methods such as microlithographic etching techniques including wet, plasma, laser or e-beam etching or the like. Additionally, the channels may be formed via mechanical methods such as milling, scribing or high pressure particle stream methods. The inlet channel 14 comprises respective feed channels 16, 18, 20, in this case provided for feed of calibrant, buffer and analyte solutions to the inlet channel 14 of the analyzer module.

Upper polymer layer is provided with inlet channel 24 which is partially positioned

over channel 14. This channel communicates with perpendicularly disposed inlet channel 24 which extends perpendicularly through the layer 4 and is positioned adjacent valve egress channel 26 which, in turn communicates with sensor channel 28. The lower portion of channel 28 is formed in the lower polymer layer.

Fluid flow between the inlet channel 24 and valve egress channel 26 is selectively controlled via movement of valve member 22 which is an integral part of valve layer 8. The valve 22 surrounds the area adjacent the bores communicating with inlet and egress channels 24, 26 respectively, which bores are perpendicularly disposed with regard to and terminate in the top planar surface of upper polymer layer 4. A valve support layer 10 constructed of rigid plastic such as polyethylene, polypropylene, polycarbonate or polyphenylsulfone is provided on top of the upper polymer layer 4. The valve support layer 10 includes a vaulted concavity 12 which is positioned directly on top of the valve 22.

In one possible mode of operation a valve actuation conduit 30 is provided so that pneumatic or hydraulic fluid in communication with the conduit will selectively apply negative or positive pressure to the conduit thereby opening and closing the valve 22. In other words, valve 22 in its open position will flex so that it will be arched upwardly in the concavity 12 (see Fig. 1C) thereby allowing fluid communication between the inlet channel 24 and valve egress channel 26. Conversely, when positive pressure is applied through the conduit 30, the valve 22 will return to a position wherein it is contiguous with the top surface of upper polymer layer 4 (Fig. 1B), thereby closing communication between the inlet 24 and egress channel 26.

In the preferred method of operation, the fluid pressure will open the valve. In this way instantaneous negative pressure is not applied to the channel fluid which can cause degassing and the creation of bubbles. Bubbles are of course very undesirable in a microfluidic due to the surface tension of the bubble and the channel wall and the resulting increase in the resistance to channel flow.

It is noted that the interfacial areas defining boundaries between the upper polymer layer 4 and lower polymer layer 6 are directly bonded together without any adhesive. Also, the polymer valve layer 8 is directly bonded to the upper layer 4 without an adhesive means in all of those interfacial regions between layers 4 and 8 save for the valve areas 22. Accordingly, considerable flex and stretch remains in the valve area 22 so that the flexible

polymer in this area may be free to flex upwardly toward the vaulted concavity 12 to open the valve and thereby provide communication between inlet 24 and egress channel 26.

Turning now to Fig. 2, there is shown lower polymer layer 6 and inlet channel 14 formed therein. Inlet channel 14 communicates respectively with calibrant branch feed channel 16, buffer feed branch channel 18, and analyte branch feed channel 20. Sensor channel 28 is in communication with valve egress channel 26.

Turning now to Fig. 3, sensor channel 28 is provided in the lower surface of upper polymer layer 4 and upper surface of layer 6. As shown in the drawing, the fluid to be analyzed passes from left to right and is in fluid flow contact with reference electrode 50, working electrode 52, and counter-electrode 54, which are formed along the sensor channel. As the fluid flows from left to right and passes over the electrodes, it flows to outlet conduit 56 and into tank 58. The outlet conduit 56 can be connected to channel 28 via snap or other quick connect mechanism to facilitate easy removal and replacement of the module 2.

As may best be seen in the magnified view, Fig. 3A, the electrodes are positioned on a plateau region 150 corresponding to the top surface of lower layer 6 within the sensor channel 28. This is accomplished by allowing a half-channel step in the sensor channel in the region of the electrodes.

It is to be remembered that although a specific electrode structure is shown in Fig. 3, other sensors could similarly be employed to contact the fluid flowing through the sensor channel. In this regard, other electrochemical or even optical sensors may be suitably disposed within sensor channel 28, in order to sense the presence or concentration of an analyte, all within the ambit of the present invention.

Turning now to Fig. 4, there is shown a sectional view of another microfluidic flow analyzer module in which a plurality of fluid flow cells are provided. Each cell is defined as including feed channel means, sensor channel means, and a valve for selectively blocking or allowing communication between the feed and sensor channels. The embodiment shown in Figs. 1A - 3 depicts a microfluidic flow analyzer module having one cell. However, in many commercial applications it will be desirable to provide a multi-cell module so that, for example, each cell may provide for analysis of a different analyte. Here, valve layer 8 includes valve areas 22a, b, and c. Underlying each area 22a, b or c are a pair of perpendicularly extending inlet and egress channel means similar to the members 24, 26



shown in Fig. 1. Each of these members terminates in a bore in the planar top surface of upper polymer layer 4. Additionally, in Fig. 4, feed conduit means have been shown for each cell and include calibrant conduits 32a, b, c, , buffer conduits 34a, b, c, and analyte conduits 36a, b, c each with its associated pump, valve and reservoir. Additionally, three outlet conduits 56a, b, and c are shown, each one associated with one of the cells. A microfluidic flow analyzer module in accordance with the invention may contain a multiplicity of feed and sensor channels with each cell performing one or a variety of analyte sensing functions.

For each cell shown in Fig. 4, the feed channel 14 thereof is provided with feed conduits 32a, b or c, 34a b, or c, 36a, b or c. These conduits are snap or otherwise matingly engaged with respective branch feed channels 16, 18, 20 (such as those shown in Fig. 1A) so that the module 2 can be readily disconnected from the analytical system and replaced with another module 2. For each of the feed conduits 32a, b or c, 34a, b or c, 36a, b or c, pumps P are provided and may be operated for example by solenoid actuation through microprocessor control. The pumps include well known peristaltic pumps that are designed to pump a metered quantity of fluid from the reservoir R connected to the pumps P by valving mechanisms V. Additionally, each of the sensor channels 28 (see Fig. 3) are operatively connected to an outlet conduit 56a, b, or c via quick connect fittings. Again, this facilitates rapid replacement of one module 2 with another.

Although external pumps, valves and resevoirs are shown in the drawings and described hereinabove for purposes of clarity and simplification, it is thought that virtually all micro fluid handling processes can be accomodated within the confines of the planar interfacial surfaces of the layers 4, 6 or 4, 8. It is presently envisioned that pressurized fluid resevoirs will be used in conjunction with restrictive membranes to accomplish the desired reagent microflow.

As indicated above, any sensing means may be utilized and substituted for the electrodes 50, 52, 54. The only criterion is that the sensor, including electrochemical and optical sensors, should be capable of measuring the analyte as it flows past the sensing element in the sensor channel of the microfluidic flow analyzer module.

Additionally, multiple analysis can be conducted in one channel by in-line series disposition of multiple sensor elements along the channel. In those cases in which electrodes such as those 50, 52, 54 are shown, they may be deposited on the plateau region 150 of the

sensor channel by photo patterning, screen printing, ink jet, or micro-syringe type methods. Further, the electrodes could be covered by one or more enzyme containing membranes and interference rejection membranes if desired. In the case in which enzymes or other sensing elements are to be disposed adjacent the electrode, these can be immobilized in a polymeric medium. The polymeric medium may be electropolymerized over the electrode by, for example, the methods reported in U.S. patents 5,540,828 and 5,286,364 to Yacynych.

The microfluidic flow analyzer module in accordance with the invention can be utilized in conjunction with a plurality of different sensing methods including electrochemical amperometric, potentiometric, or conductimetric methods. Additionally, optical sensors can be utilized in conjunction with the invention although the primary concern is to provide an amperometric glucose sensor for fermentation and cell culture media. Additionally, other analytes such as glutamine, lactate, and ammonia can be sensed using the modules of the invention.

In the specific embodiment shown herein in Figs. 1A - 3, the auxiliary electrode may comprise platinum that is deposited via sputter coating, e beam evaporation or other methods. The working electrode will comprise platinum, deposited as stated above, and this electrode may be covered with an enzyme containing a laminated structure of the type known in the art. Finally, the reference electrode may comprise a platinum base over which a silver plated film is formed followed by a chloridizing treatment to form a silver/silver chloride reference electrode.

The feed and sensing channels formed in the upper and lower polymer layers of the analyzer module may be formed in the requisite surface portions of the upper and lower polymer layers by etching via photo developed micro-lithographic patterns. For example, a suitable photo resist will be applied to the substrate and then the surface of the substrate will be aligned with a mask followed by exposure to, for example, UV radiation. The etching of the polymer coating and developing of the photoresist can be accomplished in one step with a dilute aqueous alkaline solution when a positive photoresist is used. Typical etchants are dilute solutions of NaOH, KOH, tetra-alkali ammonium hydroxide, etc. The surface is then neutralized and rinsed for example with immersion in acidic acid followed by rinsing in DI water. The photoresist can be stripped with solvents such as acetone, butyl acetate or higher acetates. The skilled artisan will be able to fashion whether a positive photoresist or a

negative resist should be used and the particular types of photo resists that can be applied. Also, etching of the desired pattern may be accomplished via normal high resolution techniques including electron beam, laser or ion beam etching.

The polyimides are preferred for use as the layers 4, 6, and 8. These polymers are available commercially in thin film form with desirable film thicknesses being on the order of about 1 - 30 mils. So that the films may be bonded without application of adhesives and the like between layers, it is most desirable to employ bondable polyimides as the layers 4, 6, and 8. Suitable adhesiveless directly bondable polyimides are reported in U.S. patent 5,525,405 (Coverdall et al.). The disclosure of this patent is incorporated by reference herein.

As is reported in the '405 patent, multiple polyimide film layers may be superimposed on and directly bonded to each other without use of an adhesive. These directly bondable polyimides are aromatic polyimides containing from about 400-10,000 parts of an inorganic bonding enhancing agent such as Sn. The films comprise the polymerization - imidization product of an aromatic tetracarboxylic dianhydride component and an aromatic diamine component.

The aromatic polyimides are commonly prepared via reaction of an aromatic dianhydride and an aromatic diamine in an organic solvent medium. This results in formation of a soluble polyamic acid. This reaction normally proceeds at room temperature and is slightly exothermic. The polyamic acid precursors are converted to polyimides by dehydration, using heat or reagents such as acetic anhydride or pyridine.

The most popular commercially available polyimide films are formed by the condensation reaction of pyromellitic dianhydride (PMDA) and oxydianiline (ODA). The reaction is illustrated in the following scheme:

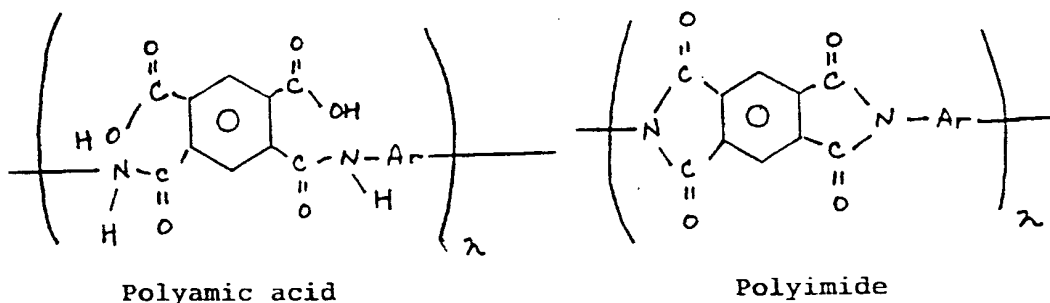
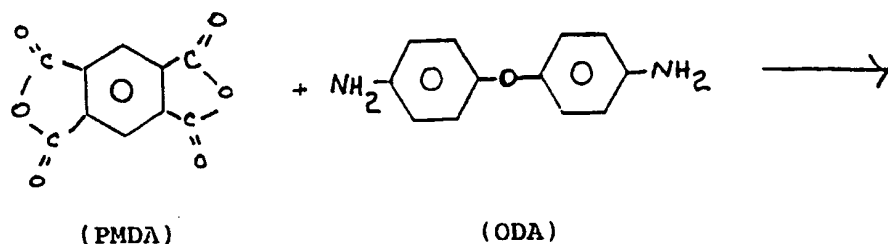

Ar = oxydianiline (i.e. 4,4'-diaminodiphenyl ether)

As is stated in the '405 patent a host of other aromatic dianhydrides and aromatic diamines can be used. Suitable dianhydrides for use in the polyimide films include: pyromellitic dianhydride; 2,3,6,7-naphthalene tetracarboxylic dianhydride; 3,3',4,4'-biphenyl tetracarboxylic dianhydride; 1,2,5,6-naphthalene tetracarboxylic dianhydride; 2,2',3,3'-biphenyl tetracarboxylic dianhydride; 3,3',4,4'-benzophenone tetracarboxylic dianhydride; 2,2-bis(3,4-dicarboxyphenyl) propane dianhydride; 3,4,9,10-perylenetetracarboxylic dianhydride; 1,1-bis(2,3-dicarboxyphenyl) ethane dianhydride; 1,1-bis(3,4-dicarboxyphenyl) ethane dianhydride; bis(2,3-dicarboxyphenyl) methane dianhydride; bis(3,4-dicarboxyphenyl) methane dianhydride; oxydiphthalic dianhydride; bis(3,4-dicarboxyphenyl) sulfone dianhydride; and the like.

Suitable aromatic diamines for use in the polyimide films include: 4,4'-diaminodiphenyl propane; 4,4'-diamino-diphenyl methane; benzidine; 3,4'-dichlorobenzidine; 4,4'-diaminodiphenyl sulfide; 3,4'-diaminodiphenyl sulfone; 3,4'-diaminodiphenyl sulfone; 4,4'-diaminodiphenyl ether; 3,4'-diaminodiphenyl ether; 1,5-diaminonaphthalene; 4,4'-

diaminodiphenyl ethyl phosphine oxide; 4,4'-diaminodiphenyl N-methyl amine; 4,4'-diaminodiphenyl N-phenylamine; 1,4-diaminobenzene (p-phenylene diamine); 1,3-diaminobenzene; 1,2-diaminobenzene; and the like.

As mentioned in the '405 patent, copolyimides can also be prepared from the above precursors. Specifically mentioned are copolyimides derived from 15-85 mole% biphenyltetracarboxylic dianhydride, 15-85 mole% pyromellitic dianhydride, 30-10 mole% p-phenylenediamine and from 0-70 mole% 4,4'-diaminodiphenyl ether. The following copolymer is mentioned as preferred:

- 30 mole% pyromellitic dianhydride
- 20 mole% 3,3',4,4' biphenyltetracarboxylic dianhydride
- 30 mole% p-phenylene diamine
- 20 mole% 4,4'-diaminodiphenyl ether

The '405 patent indicates that the organic solvents include normally liquid N, N-dialkylcarboxylamides, generally. Preferred solvents include the lower molecular weight members of such carboxylamides, particularly N,N-dimethylformamide and N,N-dimethylacetamide. Other solvents which may be used dimethylsulfoxide, N-methyl-2-pyrrolidone, tetramethyl urea, dimethylsulfone, hexamethylphosphoramide, tetramethylene sulfone, and the like. The amount of solvent used preferably ranges from 75 to 90 weight % of the poly(amid acid), since this concentration has been found to give optimum molecular weight.

The solvated poly (amic) acid is further condensed to form the desired polyimide via heating at temperatures ranging from about 50°C initially, followed by higher temperature heating of about 350 - 400°C to result in almost complete condensation of the polyamic acid intermediate to the imide form.

So as to enhance the adhesive-less bonding properties of the films a metallic bond enhancing agent such as Sn is added to the polyimide during the polymerization or film forming process. As reported in the '405 patent, Sn in the amount of about 400 - 10,000 ppm has proven effective. Reputedly, the preferred amount of Sn ranges from 1,000 - 4,000 ppm with the most preferred amount being about 1,200 - 3,500 ppm. Tin can be added as an organotin compound as described in U.S. patent 5,272,194 or a  $\text{Sn}^{-2}$  or  $\text{Sn}^{+4}$  salt as specified

in U.S. patent 5,218,034. Bis-tributyltin oxide is mentioned as a preferred organotin compound.

In accordance with the invention, the layers 4, and 6 of the microfluidic flow analyzer module are preferably composed of DuPont® XNA™ Kapton® polyimide film. This is available and advertised as an adhesiveless, self-bondable film. The preferred film thickness is 5 mils.

With regard to the valve layer 8 in accordance with the invention, preliminary investigation has indicated that this can be composed of DuPont's Kapton® KJ thermoplastic polyimide film. The preferred thickness for this film is about 1 mil.

After the layers 4 and 6 have been purchased or prepared, the lower surface of layer 4 and top surface of layer 6 are etched in accordance with conventional techniques, as stated above, to provide the required pattern which will correspond to the sensor and feed channels in the finished microfluidic flow analyzer module. The perpendicularly arranged (i.e. with respect to the surface plane) channels 24, 26 can be inserted via conventional techniques including wet, plasma, E-beam, laser drilling or similar operations. The sensor means, such as electrodes, etc. can be placed along one of the layer surfaces defining a portion of the sensor channel 28. The layers 4, 6 are then placed in superposed relation with the etched surfaces thereof in mating, interfacial engagement to define the fluid flow channels needed for fluid inlet and outlet from the feed channel through the sensor channel.

As illustrated diagrammatically in Fig. 5, the layers 4, 6 are then placed in a vacuum autoclave 100 or similar hot press apparatus. As shown, upper platen 102 is placed on top of the layers 4,6 in the autoclave with lower platen 104 on the bottom. The platens may be hydraulically driven together to form a pressure nip on the layers 4, 6.

The bonding operation may be carried out in the autoclave at temperatures of around 350 - 455°C at pressures of about 24 - 690 bar for a period of about 5 minutes to three hours. Preferably, the heat-press bonding operation is carried out under vacuum of less than 760 mm Hg. In this manner the sandwich construction providing the channel bearing layers 4, 6 is formed.

After the sandwich construction of layers 4, and 6 is provided, the valve layer 8 can be laminated over the top of the sandwich construction, again in a vacuum autoclave as shown in Fig. 5 or in another hot press. Here, bonding to the sandwich is normally carried out at about

275 - 350°C at about 200 psi under vacuum conditions.

Notably, when bonding the layer 8 to the sandwich assembly 4, 6, relief areas or apertures 122 are provided at least in the top platen 102 (as is depicted in Fig. 6). This platen (as well as the platens used in forming the original sandwich) has length and width dimensions that roughly match the dimensions of the layers 4, 6, 8. However, during the bonding of the valve layer 8 to the sandwich, the relief areas 122 overlie the valve areas 22 that will appear in the finished module. During the pressing operation, less pressure will be exerted on the laminate in the areas 122 than along the other laminate areas under the solid portions of the platen. Accordingly, the layer 8 in those areas will not readily bond to layer 4 in the valve areas. The layer 8 in those areas will remain moveable and flexible so that it will perform as a valve that upon actuation will selectively open and close communication between inlet channel 24 and valve egress channel 26. Additionally, the relief areas may be provided with vents so as to prevent build up of gas pressure from outgass products.

After the laminate consisting of layers 4, 6, and 8 is provided, the valve support layer 10 is bonded thereover by conventional means such as by use of a dry sheet adhesive or heat bonding of thin elastomer sheet in a liquid solvent medium. The microfluidic analyzer module comprising layers 4, 6, 8 and 10 can then, if desired, be mounted on a base or other mounting mechanism ready for insertion as a component of a fluid analysis system. The base may be attached/sealed to the module 2 using conventional means such as self-sticking double sided adhesive, heat-bondable sheet adhesive or through the use of an elastomeric gasket seal in combination with a glue or solvent applied to the perimeter of the rigid base and receiving structure.

The preceding description and accompanying drawings are intended to be illustrative of the invention and not limited. Various other modifications and applications will be apparent to one skilled in the art without departing from the true spirit and scope of the invention as defined by the following claims.

What is claimed is:

1. A module with fluid flow channels formed therein, comprising a first and second polymer layer, said first layer superposed over said second layer to define an interfacial area with micro-fluid channels formed along said interfacial area, said first and second polymer layers bonded directly together along said interfacial area without adhesive, said micro-fluid channels having widthwise dimensions of from about .001 - .015" and depths of about from .0005 - .015".
2. A module as recited in claim 1 wherein said fluid channels comprise a fluid inlet channel and a fluid sensing channel, and valve means operatively associated with said fluid inlet and fluid sensor channels for selectively opening and closing communication between said fluid inlet channel and said fluid sensing channel.
3. A module as recited in claim 2 wherein an analyte sensor is operatively associated with said fluid sensing channel.
4. A microfluidic analyzer module comprising:
  - (a) a first sheet of polyimide having a top surface area and a bottom surface;
  - (b) a second sheet of polyimide material having a top surface area and a bottom surface, said first and second polyimide sheets in superposed relation with said bottom surface of said first sheet of polyimide and said top surface of said second sheet of polyimide forming bonded, adhesiveless, interfacial surface areas, said interfacial surface areas comprising fluid flow channels therein.
5. A microfluidic module as recited in claim 4 wherein said flow channels comprise a feed channel and a sensor channel, said module further comprising valve means operatively associated with said feed channel and said sensor channel for selectively opening and closing communication between said feed channel and said sensing channel, and a sensing element disposed in said sensor channel to detect the presence or concentration of an analyte in said sensor channel.



6. A microfluidic analyzer module as recited in claim 5 wherein said feed channel comprises a feed channel bore extending upwardly through said first sheet of polyimide and terminating in said top surface of said first sheet of polyimide, said sensor channel comprising a sensor channel bore extending upwardly through said first sheet of polyimide and terminating in said top surface of said first sheet of polyimide proximate said feed channel bore, said valve means comprising a flexible material positioned over said feed channel bore and said sensor channel bore, actuation means connected to said valve means for pressing said flexible material over said feed channel bore and said sensor channel bore to block communication therebetween and for relaxing said flexible material in spaced relation over said top surface of said first sheet of polyimide for opening communication therebetween.
7. A microfluidic analyzer module as recited in claim 6 wherein said sensing element comprises an electrochemical sensing element.
8. A microfluidic analyzer module as recited in claim 6 wherein said sensing element comprises an optical sensing element.
9. A microfluidic analyzer module as recited in claim 7 wherein said electrochemical sensing element comprises an electrode.
10. Laminated microfluidic analyzer assembly module comprising a first, second and third layer of polymeric material, said first and second layers directly bonded together without adhesive to form a sandwich structure having a top surface and a bottom surface, said sandwich structure comprising a fluid flow channel formed therein, said fluid flow channel being in communication with said top surface of said sandwich structure, a valve region of said top surface in operative association with said fluid flow channel, said third layer of polymeric material superposed over said top surface of said sandwich structure, a portion of said third polymeric material overlying said valve region to define a valve, said third layer of polymeric material comprising a flexible plastic material bonded over said top surface of said sandwich structure except for said valve, said third layer of polymeric material retaining its flexibility at said valve, and a valve actuator operatively associated with said valve for

selectively closing and opening said valve.

11. Laminated microfluidic analyzer module as recited in claim 10 wherein said third layer is directly, non-adhesively bonded to said top surface of said sandwich structure.
12. Laminated microfluidic analyzer module as recited in claim 11 wherein said first, second and third layers of polymeric material include polyimide polymers.
13. Laminated microfluidic analyzer module as recited in claim 10 further including a fourth layer overlying said third layer, said fourth layer comprising a concave surface portion overlying said valve in said third layer.
14. Laminated microfluidic analyzer module as recited in claim 13 wherein said valve actuator comprises a pressure source communicating with said concave surface portion.

FIG-1A

1/3

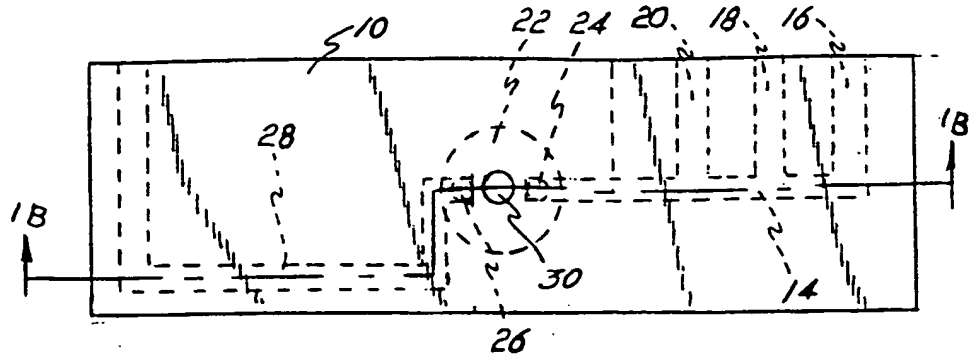

FIG-1B

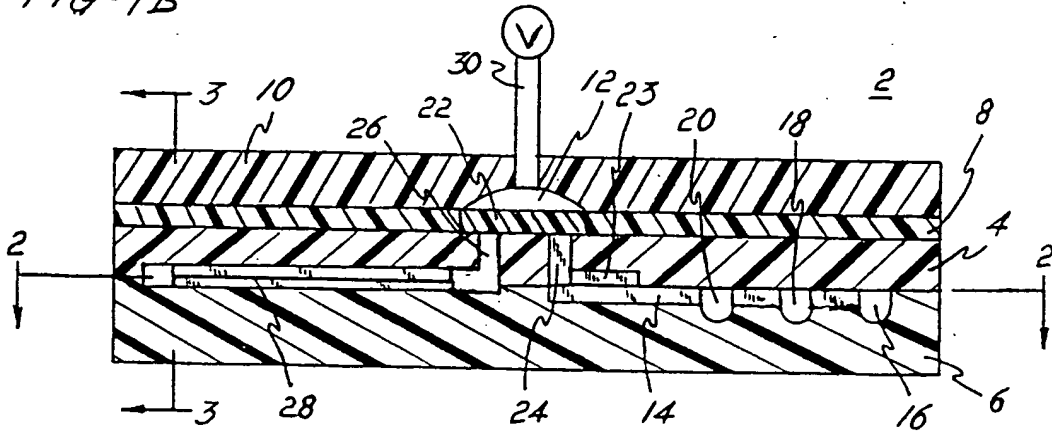

FIG-1C

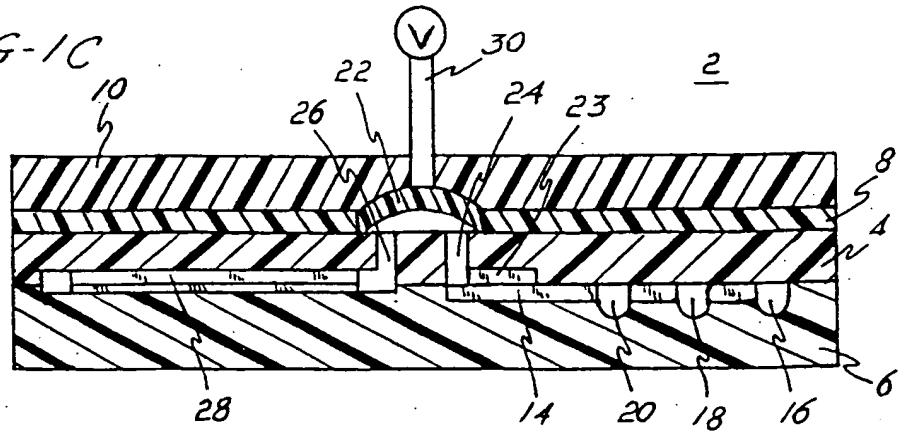

FIG-2

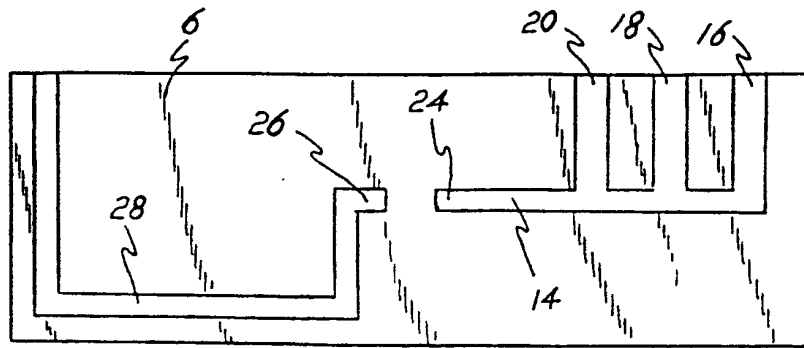

FIG-3

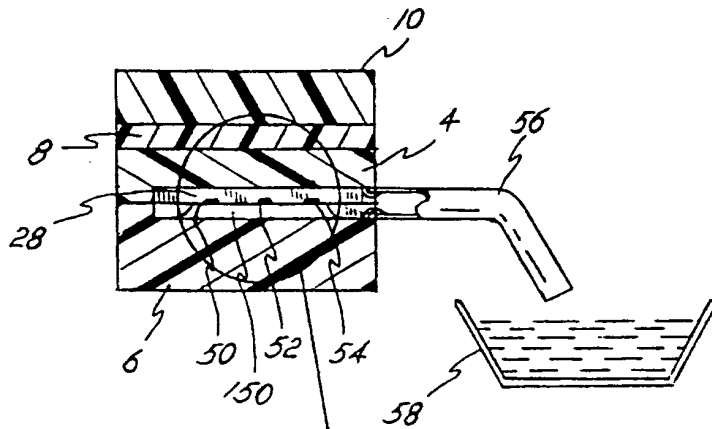

FIG-3A

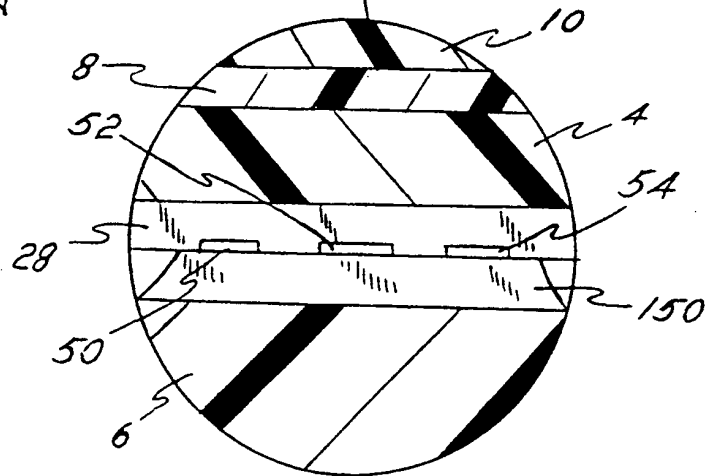

FIG-4

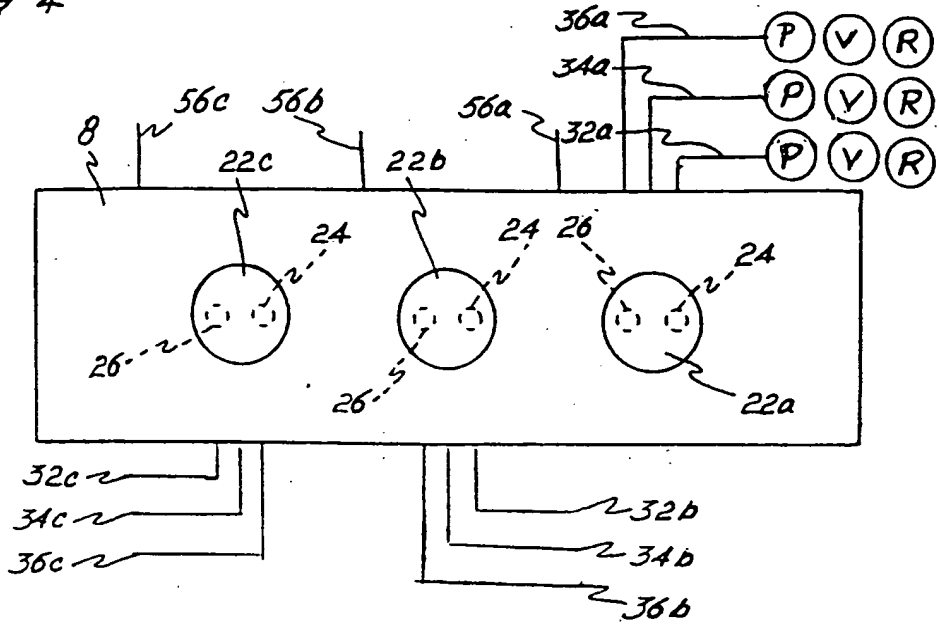

FIG-5

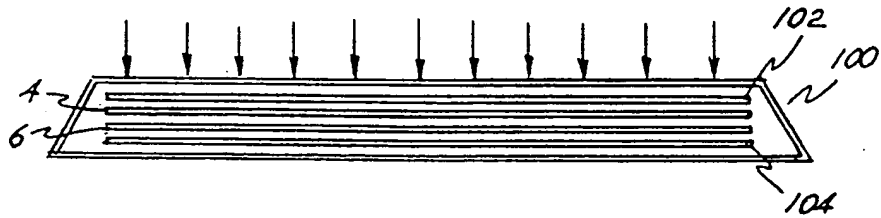
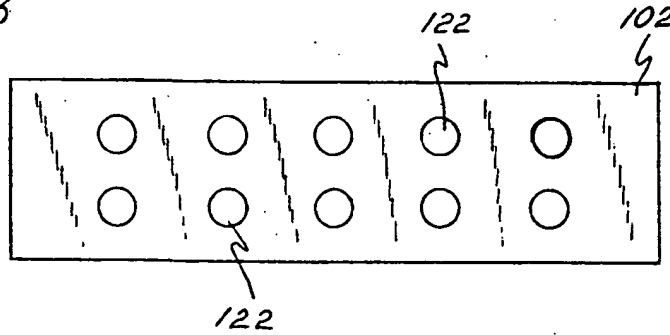

FIG-6



# INTERNATIONAL SEARCH REPORT

Internat. Application No  
PCT/US 98/14950

<b>A. CLASSIFICATION OF SUBJECT MATTER</b> IPC 6 B01L3/00 B32B27/34				
According to International Patent Classification(IPC) or to both national classification and IPC				
<b>B. FIELDS SEARCHED</b>				
Minimum documentation searched (classification system followed by classification symbols) IPC 6 B01L				
Documentation searched other than minimum documentation to the extent that such documents are included in the fields searched				
Electronic data base consulted during the international search (name of data base and, where practical, search terms used)				
<b>C. DOCUMENTS CONSIDERED TO BE RELEVANT</b>				
Category	Citation of document, with indication, where appropriate, of the relevant passages	Relevant to claim No.		
X A X Y  Y	EP 0 770 871 A (HEWLETT PACKARD CO) 2 May 1997 see column 6, line 55 - column 7, line 16 see column 11, line 30 - line 40 see column 9, line 53 - column 10, line 7 see column 12, line 11 - line 26; figure 1 see column 12, line 44 - column 13, line 38 see column 16, line 37 - column 17, line 8; figures 6,7 --- W0 95 08716 A (ROSEMOUNT ANALYTICAL INC) 30 March 1995 see page 5, line 20 - page 8, line 20: figures see page 10, line 23 - page 11, line 11 --- -/--	1  1,4  1,4 2,3,5-9  2,3,5-9		
<input checked="" type="checkbox"/> Further documents are listed in the continuation of box C. <span style="margin-left: 200px;"><input checked="" type="checkbox"/> Patent family members are listed in annex.</span>				
* Special categories of cited documents :				
<table style="width: 100%; border: none;"> <tr> <td style="width: 50%; border: none; vertical-align: top;">                     "A" document defining the general state of the art which is not considered to be of particular relevance                      "E" earlier document but published on or after the international filing date                      "L" document which may throw doubts on priority claim(s) or which is cited to establish the publication date of another citation or other special reason (as specified)                      "O" document referring to an oral disclosure, use, exhibition or other means                      "P" document published prior to the international filing date but later than the priority date claimed                 </td> <td style="width: 50%; border: none; vertical-align: top;">                     "T" later document published after the international filing date or priority date and not in conflict with the application but cited to understand the principle or theory underlying the invention                      "X" document of particular relevance; the claimed invention cannot be considered novel or cannot be considered to involve an inventive step when the document is taken alone                      "Y" document of particular relevance; the claimed invention cannot be considered to involve an inventive step when the document is combined with one or more other such documents, such combination being obvious to a person skilled in the art.                      "&amp;" document member of the same patent family                 </td> </tr> </table>			"A" document defining the general state of the art which is not considered to be of particular relevance "E" earlier document but published on or after the international filing date "L" document which may throw doubts on priority claim(s) or which is cited to establish the publication date of another citation or other special reason (as specified) "O" document referring to an oral disclosure, use, exhibition or other means "P" document published prior to the international filing date but later than the priority date claimed	"T" later document published after the international filing date or priority date and not in conflict with the application but cited to understand the principle or theory underlying the invention "X" document of particular relevance; the claimed invention cannot be considered novel or cannot be considered to involve an inventive step when the document is taken alone "Y" document of particular relevance; the claimed invention cannot be considered to involve an inventive step when the document is combined with one or more other such documents, such combination being obvious to a person skilled in the art. "&" document member of the same patent family
"A" document defining the general state of the art which is not considered to be of particular relevance "E" earlier document but published on or after the international filing date "L" document which may throw doubts on priority claim(s) or which is cited to establish the publication date of another citation or other special reason (as specified) "O" document referring to an oral disclosure, use, exhibition or other means "P" document published prior to the international filing date but later than the priority date claimed	"T" later document published after the international filing date or priority date and not in conflict with the application but cited to understand the principle or theory underlying the invention "X" document of particular relevance; the claimed invention cannot be considered novel or cannot be considered to involve an inventive step when the document is taken alone "Y" document of particular relevance; the claimed invention cannot be considered to involve an inventive step when the document is combined with one or more other such documents, such combination being obvious to a person skilled in the art. "&" document member of the same patent family			
Date of the actual completion of the international search  <p style="text-align: center;">27 October 1998</p>		Date of mailing of the international search report  <p style="text-align: center;">05/11/1998</p>		
Name and mailing address of the ISA European Patent Office, P.B. 5818 Patentlaan 2 NL - 2280 HV Rijswijk Tel. (+31-70) 340-2040, Tx. 31 651 epo nl, Fax: (+31-70) 340-3016		Authorized officer  <p style="text-align: center;">Hocquet, A</p>		

# INTERNATIONAL SEARCH REPORT

Internat. Application No

PCT/US 98/14950

C.(Continuation) DOCUMENTS CONSIDERED TO BE RELEVANT		
Category	Citation of document, with indication, where appropriate, of the relevant passages	Relevant to claim No.
A	US 4 869 282 A (SITTLER FRED C ET AL) 26 September 1989 see column 4, line 54 - column 5, line 3 see column 6, line 25 - line 35 ---	2,5,10
X	WO 97 02357 A (AFFYMETRIX INC ;ANDERSON ROLFE C (US); LIPSHUTZ ROBERT J (US); RAV) 23 January 1997 see page 32, line 24 - page 33, line 38 see page 34, line 31 - page 35, line 9 see page 36, line 1 - line 7 see page 36, line 34 - line 32; figure 2B see page 8, line 27 - line 31 ---	1-9
X	see page 36, line 34 - line 32; figure 2B	10
X	see page 8, line 27 - line 31	7-9
X	US 5 478 751 A (OOSTA GARY M ET AL) 26 December 1995 see column 2, line 25 - line 31 see column 9, line 58 - column 10, line 5 ---	1
A	EP 0 394 048 A (BIOTRACK INC) 24 October 1990 see column 5, line 7 - line 29; figures ---	1,4,10
A	EP 0 716 918 A (DU PONT) 19 June 1996 cited in the application see page 1, line 15 - line 25; claim 1 ---	1,4,10
A	WO 94 21386 A (RES CORP TECHNOLOGIES INC) 29 September 1994 see page 3, line 22 - line 30 see page 5, line 3 see page 30, line 10 - line 29 see page 34, line 15 - line 28 ---	1,4,10
A	WO 97 21090 A (GAMERA BIOSCIENCE) 12 June 1997 see page 24, line 20 - page 27, line 10; figures 6-11 -----	13

# INTERNATIONAL SEARCH REPORT

Information on patent family members

Internat. Application No

PCT/US 98/14950

Patent document cited in search report	Publication date	Patent family member(s)	Publication date
EP 0770871 A	02-05-1997	US 5641400 A	24-06-1997
WO 9508716 A	30-03-1995	CA 2169826 A CN 1133080 A JP 9505130 T	30-03-1995 09-10-1996 20-05-1997
US 4869282 A	26-09-1989	CA 2004965 A DE 68921892 D DE 68921892 T EP 0447451 A WO 9006470 A	09-06-1990 27-04-1995 23-11-1995 25-09-1991 14-06-1990
WO 9702357 A	23-01-1997	AU 6404996 A EP 0843734 A	05-02-1997 27-05-1998
US 5478751 A	26-12-1995	AU 1446195 A CA 2178505 A EP 0737105 A JP 9507572 T WO 9517966 A	17-07-1995 06-07-1995 16-10-1996 29-07-1997 06-07-1995
EP 0394048 A	24-10-1990	US 4952373 A AT 112509 T AU 618461 B AU 5249490 A CA 1334737 A CA 2013695 A DE 69013043 D DE 69013043 T ES 2064623 T JP 2561364 B JP 3041361 A	28-08-1990 15-10-1994 19-12-1991 22-11-1990 14-03-1995 21-10-1990 10-11-1994 04-05-1995 01-02-1995 04-12-1996 21-02-1991
EP 0716918 A	19-06-1996	US 5525405 A JP 8224845 A	11-06-1996 03-09-1996
WO 9421386 A	29-09-1994	US 5686548 A US 5686549 A	11-11-1997 11-11-1997
WO 9721090 A	12-06-1997	AU 1283397 A	27-06-1997



# INTERNATIONAL SEARCH REPORT

Information on patent family members

Internatic Application No

PCT/US 98/14950

Patent document cited in search report	Publication date	Patent family member(s)	Publication date
WO 9721090 A		EP 0865606 A	23-09-1998
		NO 982563 A	05-08-1998
		AU 4144897 A	06-03-1998
		WO 9807019 A	19-02-1998

---

**BLANK PAGE**